

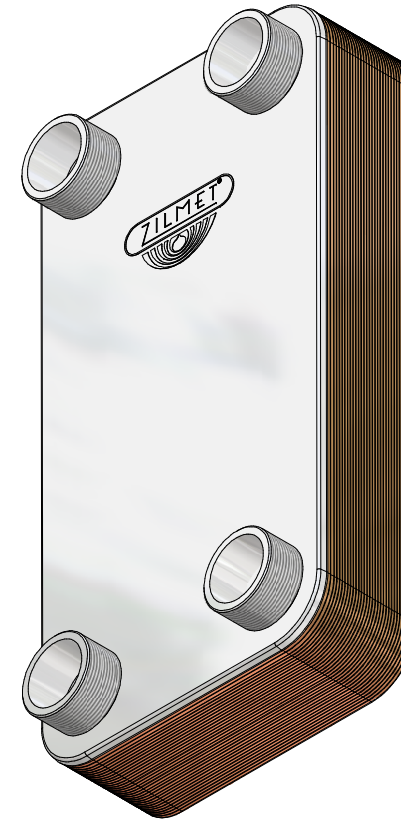

CODE	N° OF PLATES	H
17B4503004	30	80
17B4504004	40	103
17B4505004	50	127
17B4508004	80	197
17B4501004	100	244

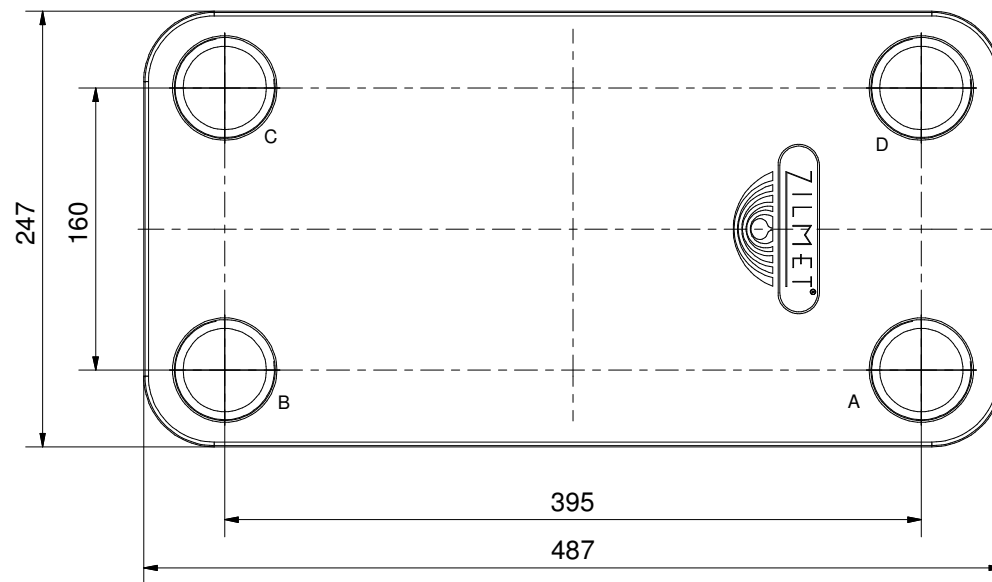

Pressione max esercizio / Max operating pressure: 30 bar
 Temperatura esercizio / Max operating temperature: -50/+200 °C
 Materiale / Material: INOX AISI 316L
 Materiale di brasatura / Brazing material: 99.9% Cu

CIRCOLAZIONE FLUIDI CIRCUITO PRIMARIO ENTRATA IN C - USCITA IN D / PRIMARY CIRCUIT IN C - OUT D
 CIRCUITO SECONDARIO ENTRATA IN A - USCITA IN B / SECONDARY SANITARY CIRCUIT IN A - OUT B

 <small>S.P.A.</small> <small>35010 Limena (PD) Via del Santo 242 tel.049/7664901</small>	DRAWING N° ZB 450		SCALE		CODICE / CODE 17B450--04
	Denominazione / Denomination SCAMBIATORE DI CALORE SALDOBRASATO (HEAT EXCHANGERS)	Drawn _____ Date	Date _____ Date	Signature _____ Signature	
	Checked _____ Date	Date _____ Date	Signature _____ Signature		
	Approved _____ Date	Date _____ Date	Signature _____ Signature		